

SO3050PE/S/P



### CARACTERÍSTICAS

El sistema de doble convección de Wolf proporciona un calor uniforme y fiable, reduce los puntos fríos y calientes y permite cocinar en varias parrillas de forma uniforme.

Elimine las dudas a la hora de cocinar con los 10 modos de cocción creados por el chef: hornear, asar, convección, rostizar por convección, deshidratar, Gourmet, fermentación, rostizar, piedra y calentamiento.

El modo Gourmet ofrece casi 50 configuraciones preestablecidas para cocinar de forma automática una variedad de deliciosos e impresionantes platos

La pantalla táctil a todo color de tamaño grande y los controles táctiles de acero inoxidable son intuitivos y fáciles de leer

La sonda de temperatura le alerta cuando su plato ha alcanzado la temperatura deseada

El horno cuenta con funciones de autolimpieza, inicio retardado, programación de cocción y función Shabat

La función Wi-Fi le permite precalentar, seleccionar modos y ajustar la temperatura del horno a distancia desde su dispositivo móvil.

Se combina con otros Sub-Zero, Wolf y Cove electrodomésticos para crear un aspecto armonioso en la cocina

Saque el mayor provecho posible de su horno aplicando los consejos y las recetas de la guía Dominar el horno de la serie E

### ACCESORIOS

Bandeja de horno de primera calidad de 30"

Kit de deshidratación

Kit de instalación doble

Kit de piedra para hornear

Parrilla para asar de 30"

Rejilla de horno estándar

Rejilla de rodamientos de extensión completa

Rejillas de horno estándar de 30"

Sonda de temperatura

Accesorios disponibles a través de un distribuidor autorizado. Para obtener información sobre los distribuidores locales, visite [subzero-wolf.com/locator](http://subzero-wolf.com/locator).



**ESPECIFICACIONES DEL PRODUCTO**

Modelo	SO3050PE/S/P
Dimensiones	29 7/8"W x 28 1/2"H x 23"D
Dimensiones interiores del horno 1	25 1/4"W x 17 1/2"H x 18 1/2"D
Capacidad general	4.7 cu. ft.
Capacidad utilizable	3.1 cu. ft.
Espacio de la puerta	21 3/8"
Peso	257 lbs
Suministro eléctrico	grounded, 240/208 VAC, 60 Hz
Servicio eléctrico	Circuito dedicado de 30 amperes
Longitud del conducto	4 Feet

**DIMENSIONES**

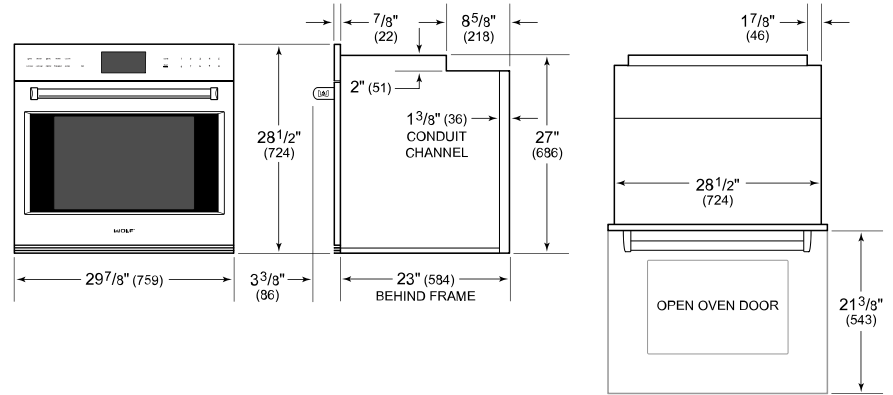

**INSTALACIÓN ELÉCTRICA**

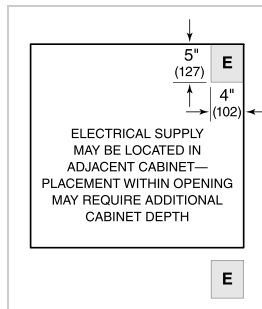

**NOTE:** Dimensions in parenthesis are in millimeters unless otherwise specified

**STANDARD INSTALACIÓN**

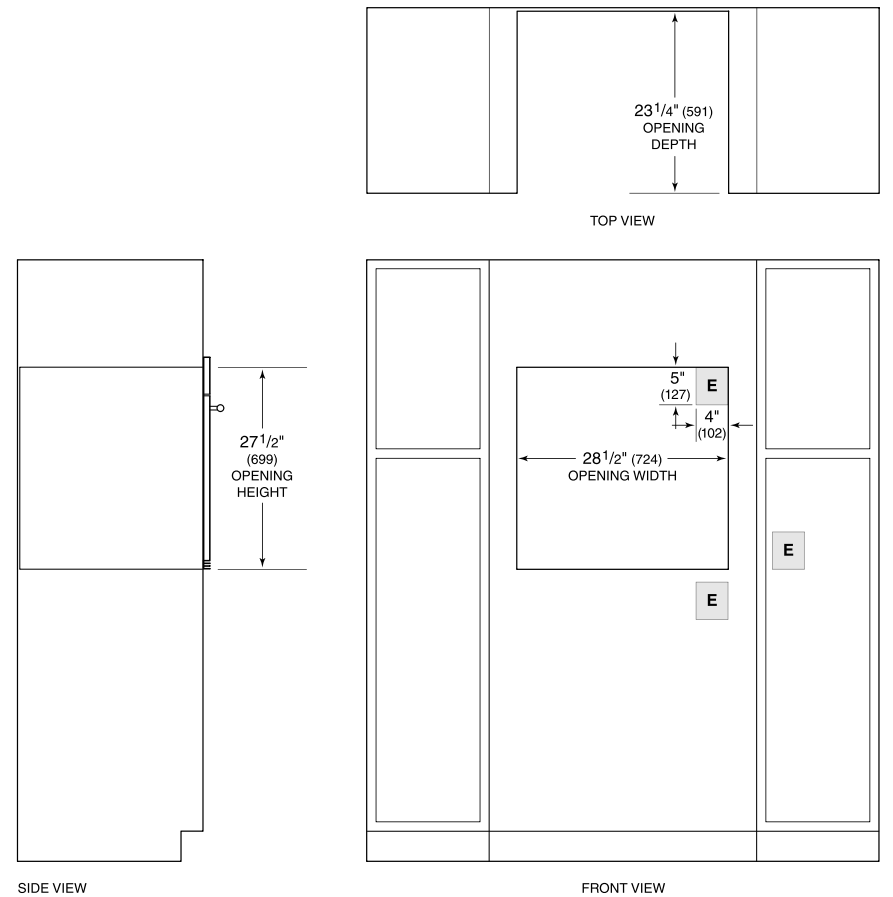

**NOTE:** Location of electrical supply within opening may require additional cabinet depth.