

INSTALLATION GUIDE

Fryer Module



Contents

Wolf Fryer Module	3
Fryer Module Specifications	4
Fryer Module Installation	8
Service Information	10

Features and specifications are subject to change at any time without notice. Visit wolfappliance.com/specs for the most up-to-date information.

IMPORTANT NOTE: Throughout this guide, dimensions in parentheses are millimeters unless otherwise specified.

Important Note

To ensure the safe and efficient use of Wolf equipment, please take note of the following types of highlighted information throughout this guide:

IMPORTANT NOTE highlights information that is especially important.

CAUTION signals a situation where minor injury or product damage may occur if instructions are not followed.

WARNING states a hazard that may cause serious injury or death if precautions are not followed.



Fryer Module Installation

IMPORTANT NOTE: Installation of the Wolf electric fryer module must be completed by a qualified installer.

Read this entire installation guide prior to installation and save for the local inspector's reference. The homeowner should keep this installation guide for future reference.

This appliance must be installed in accordance with National Electrical Codes, as well as all state, municipal and local codes. The correct voltage, frequency and amperage must be supplied to the appliance from a dedicated, grounded circuit which is protected by a properly sized circuit breaker or time delay fuse. The proper voltage, frequency, and amperage ratings are listed on the product rating plate.

Record the model and serial numbers before installing the fryer module. Both numbers are listed on the product rating plate, located on the underside of the module. Refer to the illustration below.

Wolf Fryer Module	
Model Number	IF15/S
Serial Number	

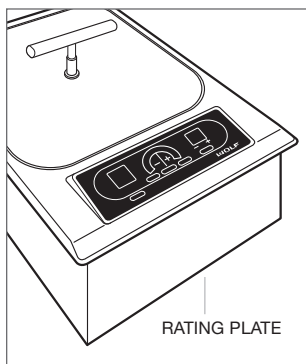

Location of rating plate.

Overall Dimensions

FRYER MODULE

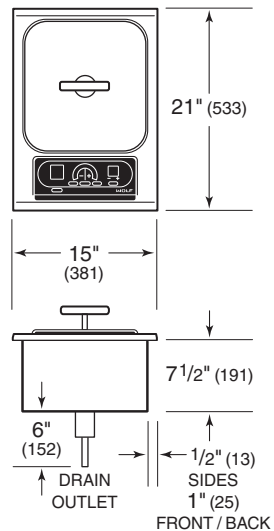

Installation Specifications

⚠ WARNING

Failure to locate the fryer module without the proper clearances will result in a fire hazard.

IMPORTANT NOTE: Installation of the Wolf electric fryer module must meet minimum clearance requirements shown in the installation illustration on page 6.

The Wolf fryer module is intended for indoor use. It is designed to fit a standard 24" (610) deep base cabinet with 25" (635) deep countertop. Before making the countertop cut-out, verify that the module will clear the side walls of the base cabinet.

It is recommended that you use a Wolf cooktop ventilation hood, pro hood or hood liner with the fryer module. Refer to the Wolf design guide.

IMPORTANT NOTE: Wolf does not recommend the use of downdraft ventilation with the fryer module.

MANUAL DRAIN OUTLET

IMPORTANT NOTE: The fryer module must be installed in a base cabinet that allows access to the manual drain valve for draining the oil. A heat-resistant bucket must be positioned under the drain outlet to accept the oil. The bucket must have a minimum 2 gallon (7.6 L) capacity. Refer to the installation illustration on page 6 for location of the manual drain outlet.

Electrical Requirements

⚠ WARNING

Verify that power is disconnected from the electrical box before proceeding.

The Wolf electric fryer module requires a separate, grounded 3-wire electrical supply with its own circuit breaker. Locate the electrical supply within the shaded area shown in the installation illustration on the following page.

MODEL IF15/S

- **Power supply:** 240/208 V AC, 60 Hz, 15 amp service.
- **Max connected load:** 2.6 kW at 240 V, 1.9 kW at 208 V.

The fryer module is provided with a 4' (1.2 m) flexible 3-wire conduit that makes a connection to a junction box. The conduit consists of two insulated hot lead conductors and one insulated ground conductor.

IMPORTANT NOTE: You must follow all National Electrical Code regulations. In addition, be aware of local codes and ordinances when installing your service.

For electrical installation, attach the conductors to the residence wiring in accordance with National Electrical Codes and all state, provincial, municipal and local codes.

The wiring diagram covering the control circuit is located inside the module control box.

IMPORTANT NOTE: This appliance must be installed in accordance with National Electrical Codes, as well as all state, municipal and local codes. The correct voltage, frequency and amperage must be supplied to the appliance from a dedicated, grounded circuit which is protected by a properly sized circuit breaker or time delay fuse. The proper voltage, frequency, and amperage ratings are listed on the product rating plate located on the underside of the module. Refer to the illustration on page 3.

⚠ WARNING

The complete appliance must be properly grounded at all times when electrical power is applied.

Do not ground the appliance with the neutral (white) house supply wire. A separate ground wire must be utilized.

If aluminum house supply wiring is utilized, splice the appliance copper wire to the aluminum house wiring using special connectors designed and agency certified for joining copper and aluminum. Follow the connector manufacturer's recommended procedure carefully. Improper connection can result in a fire hazard!

Installation Specifications

FRYER MODULE

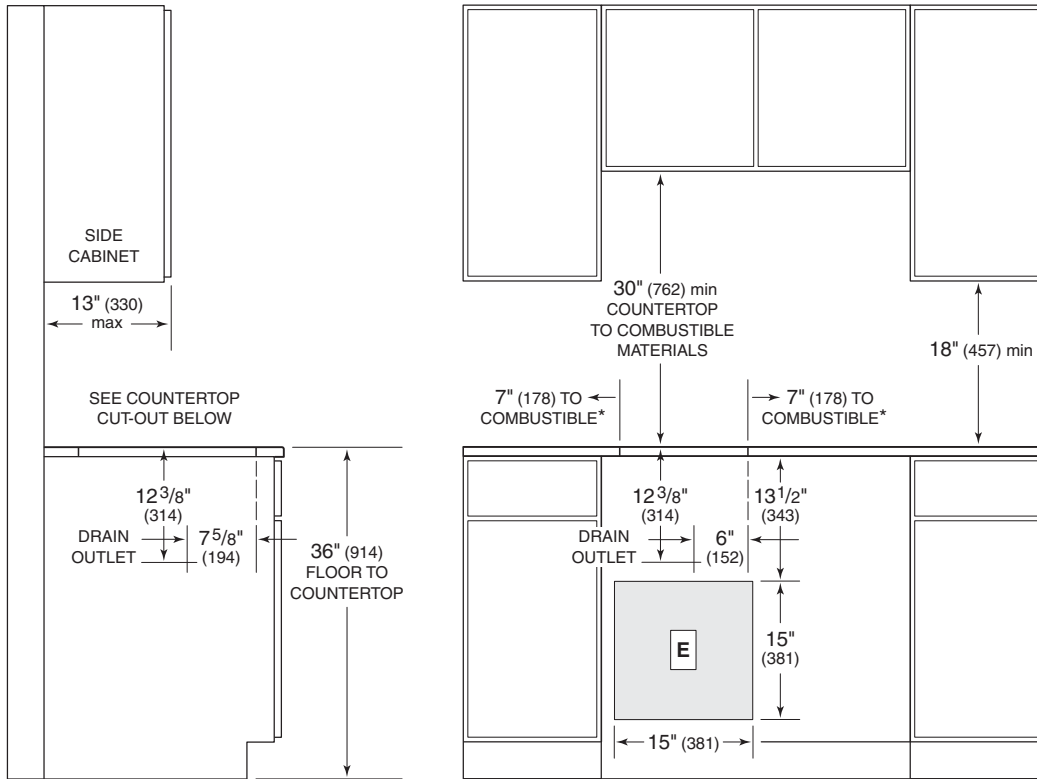

*Minimum clearance from cooktop cut-out to combustibles up to 18" (457) above countertop.

NOTE: Fryer module must be installed in base cabinet with access to valve at bottom of unit to drain oil into heat-resistant receptacle. Application shown allows for installation of two 15" (381) modules side by side.

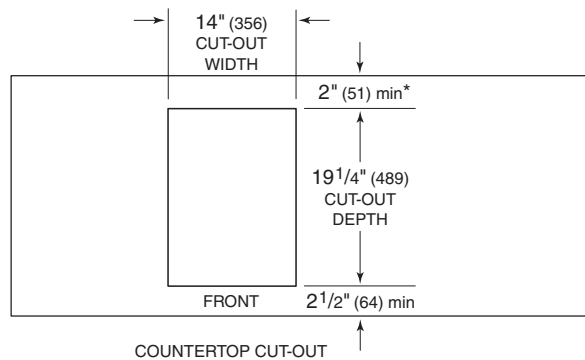

Installation Specifications

MULTIPLE COOKTOP INSTALLATION

If the fryer module is to be used in combination with additional cooktops or modules with a filler strip, refer to the chart below for the countertop cut-out width. The dimensions are derived by adding an additional 1 1/4" (32) for each additional unit, to give you the total countertop cut-out width. Dimensions include the filler strip.

When multiple cooktops are installed side by side, each unit must have its own separate, recommended electrical circuit.

When two or more cooktops or modules are installed together, an integrated module filler strip is recommended. The filler strip and other accessories are available through your authorized Wolf dealer. To obtain local dealer information, visit the find a showroom section of our website, wolfappliance.com.

IMPORTANT NOTE: Review specific installation instructions for product to product capabilities.

▲ WARNING

The fryer module must be installed at least 15" (381) from any open-flame cooking device or a Wolf steamer module. The open flame may cause ignition of oil, and contact between water and hot oil may cause burns.

Multiple Cooktops

COUNTERTOP CUT-OUT	WIDTH
2 Modules	29 1/4" (743)
3 Modules	44 1/2" (1130)
4 Modules	59 3/4" (1518)
30" (762) Cooktop / Module	44 1/4" (1124)
30" (762) Cooktop / 2 Modules	59 1/2" (1511)
36" (914) Cooktop / Module	50 1/4" (1276)

Install the Module

Remove the fryer module from its shipping carton and discard packing materials.

Lower the fryer module into the countertop cut-out opening. Center the module in the opening and check that the front edge of unit is parallel to the front edge of the countertop. Check that all minimum clearances are met. Using a pencil, outline the rear edge of the module frame on the countertop. Remove the module from the opening.

IMPORTANT NOTE: When repositioning the module in the countertop opening, lift the entire unit up from the opening to prevent scratching the countertop.

Apply the foam strip, included in the hardware package, to the underside of the module frame. Refer to the illustration below.

Reinsert the fryer module into the countertop opening. Align the rear edge of the module frame with the pencil line and check that it is parallel to the front edge of the countertop. Lift the entire module to make adjustments.

To attach the brackets to the sides of the module, insert the clip into the rectangular punchout in the pan, and push down. Install the clamping screw into the bracket and tighten until the screw contacts the underside of the countertop. Do not overtighten screws. Refer to the illustration below.

IMPORTANT NOTE: Do not seal the fryer module to the countertop. It must be removed if service is necessary.

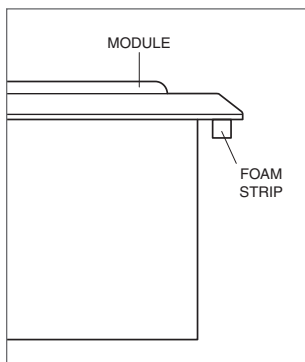

Foam strip.

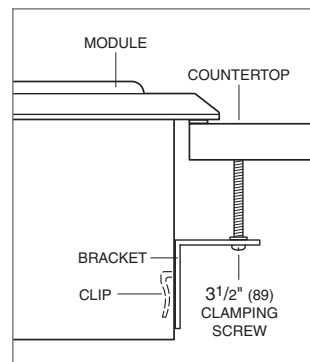

Installation brackets.

Before Operating

Read the entire Wolf fryer module use & care guide included with the unit. It contains important safety, operation, service and warranty information.

Before operating, clean the fryer module thoroughly with hot water and a mild detergent. Rinse and dry with a soft cloth. This removes any residual oil and grease left on the surface from the manufacturing process. Refer to care recommendations in the use & care guide.

⚠ CAUTION

Never operate the fryer module without oil; damage to the unit may result. Oil must be added to the fryer basin before turning the module on.

Module Removal

⚠ WARNING

The fryer module must be disconnected from the electrical supply before removal.

IMPORTANT NOTE: Removal of the fryer module should only be performed by a Wolf authorized service center technician.

If removing the fryer module is necessary for cleaning or service, first disconnect the electrical supply. Remove the mounting brackets on each side of module and remove. To reinstall, follow the steps on the previous page.

Troubleshooting

IMPORTANT NOTE: If the fryer module does not operate properly, follow these troubleshooting steps:

- Verify that electrical power is being supplied to the module.
- Check the electrical connections to ensure that the installation has been completed correctly.
- Follow troubleshooting procedures outlined in the Wolf fryer module use & care guide.
- If the module still does not operate properly, contact a Wolf authorized service center. Do not attempt to repair the module yourself. Wolf is not responsible for service required to correct a faulty installation.

Service Information

If service is necessary, maintain the quality built into your fryer module by calling a Wolf authorized service center.

To obtain the name and number of a Wolf authorized service center, check the contact & support section of our website, wolfappliance.com or call Wolf customer service at 800-332-9513.

When calling for service, you will need the fryer module model and serial numbers. Both numbers are listed on the product rating plate located on the underside of the module. Refer to the illustration below for the location of the rating plate.

IMPORTANT NOTE: Installation and service must be performed by a qualified installer or service agency. Warranty service must be performed by a Wolf authorized service center.

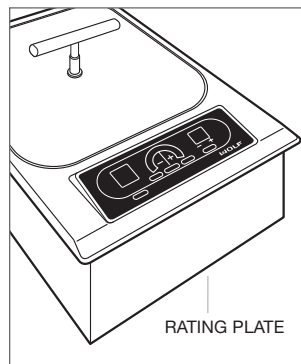

Location of rating plate.



The information and images in this guide are the copyright property of Wolf Appliance, Inc. Neither this guide nor any information or images contained herein may be copied or used in whole or in part without the express written permission of Wolf Appliance, Inc. ©Wolf Appliance, Inc. all rights reserved.

Wolf, Wolf & Design, Wolf Gourmet, W & Design and the color red as applied to knobs are registered trademarks and service marks of Wolf Appliance, Inc. Sub-Zero, Sub-Zero & Design, Dual Refrigeration, Constant Care and The Living Kitchen are registered trademarks and service marks of Sub-Zero, Inc. (collectively, the "Company Marks.") All other trademarks or registered trademarks are property of their respective owners in the United States and other countries.



WOLF APPLIANCE, INC. P. O. BOX 44848 MADISON, WI 53744 WOLFAPPLIANCE.COM 800.332.9513

816177 REV-A

8/2010

